

MODELS: ESC50	ESC50CR	GLASS FROSTER COUNTER: ESC Series
----------------------	----------------	---



ESC50



ESC50CR

General Strengths

- ✓ **Sanitation.** The interior cabinet is built with rounded corners (extensive radius for easy cleaning). Quick ability to take off shelves and slides for interior cleaning.
- ✓ **Doors & Drawers.** Self-closing door system with permanent pressure. Stay open feature included when door remains open after 95 degrees. All doors and drawers include triple chamber door gaskets, easy to remove and snap in. Doors are field reversible.
- ✓ **Control systems.** Higher precision in managing temperature settings. Greater ability to adjust of temperature ranges as per the end user's requirement.
- ✓ **100% Tested.** All condenser units are tested 100%, in helium chambers to refrigerant leak detections.
- ✓ **Certified.** AENOR audited and certified by internationally recognized firm. ISO 9001:2008 (Quality); ISO 14001:2004 (Environmental); OSHAS 18001:2007 (Prevention and Worker Safety). Audited and Certified by INTERTEK for compliance with UL 471 and NSF 7.
- ✓ **Lighting.** LED lighting in the canopy and cabinet sides reduces the energy consumption by 80% and 90% compared to a traditional bulb. Provides a much better light quality.

MODELS	Dimensions (mm)			Nº Doors	Nº Shelves	Chamber Volume (L)	Gross Volume (L)	Regimen Temp. (°C)	Ref.	Ref. Weight (gr.)	Net Weight (Kg.)
	Width	Depth	High								
ESC50	570	600	850	1	2	95	290	-18°C / -5°C	R404A	275	54
ESC50CR	570	600	850	1	2	95	290	-10°C / -5°C	R404A	275	54

WE RESERVE THE RIGHT TO CHANGE SPECIFICATIONS WITHOUT PRIOR NOTICE

MODELS: ESC50 ESC50CR	GLASS FROSTER COUNTER: <i>ESC Series</i>
--	--

STANDARD FEATURES

➤ **Exterior**

- AISI 304 Series Stainless Steel.

➤ **Interior**

- AISI 304 Series Stainless Steel,
- Wide rounded corners to aid cleaning,
- LED lighting (CR).

➤ **Insulation**

- Insulation by free CFC's polyurethane foam high-pressure injected with density 40 Kg/m³.
- Zero ODP and Low GWP.

➤ **Doors**

- Doors with integrated handle and blocked opening hinge.
- Interior of door inserted with a triple chamber door gasket easy to remove.
- Doors with double glass (6-15-5).
- Door opening of 450x410 mm.
- Door thickness of 60 mm and interior door of 50 mm.

➤ **Shelves**

- (2) interior shelves of 400x430 mm,
- Guides and shelves easy to take off for cleaning.

➤ **Refrigeration**

- Temperature regulated by a digital controller,
- Manual defrost,
- System of ventilated condensation *INFRICOOL*®,
- System of Static Evaporation,
- Climate class 4 (30°C, 55HR).

➤ **Electrical**

- Electrical connection: 220 V / 1 ph / 50 Hz



OPCIONAL

- Wire shelf,
- Set of guides,
- Electrical connection 220 V / 1 ph / 60 Hz.
- Electrical connection 115 V / 1 ph / 60 Hz.

MODELS	Dimensions Palletizing (mm)			Crated Weight (Kg.)	Power (W)	Comp. (HP)	Cooling Power (W to -10°C)	Cons. (kWh/24h)	Inten. (A)	Nivel Ruido (dB)	Container 20'/40'/40'HC	Trailer
	Width	Depth	High									
ESC50	630	620	1010	60	390	1/3	258	6,1	2,22	53,9	54 / 114 / 114	126
ESC50CR	630	620	1010	60	410	1/3	258	7,4	2,33	53,9	54 / 114 / 114	126

WE RESERVE THE RIGHT TO CHANGE SPECIFICATIONS WITHOUT PRIOR NOTICE



MODELS: ESC50 ESC50CR	GLASS FROSTER COUNTER: ESC Series
-------------------------------------	--

PLAN VIEW

ELEVATION

PLAN VIEW

RIGHT VIEW

ESC50

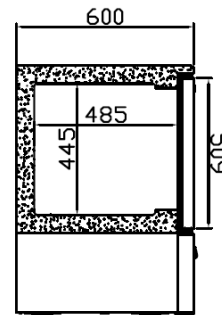
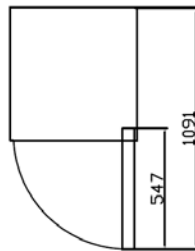
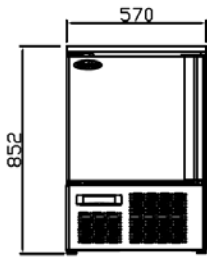

ESC50CR

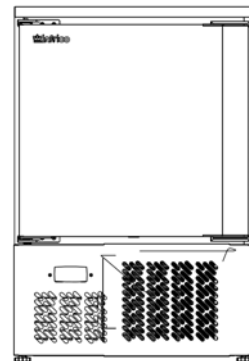
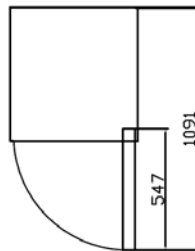
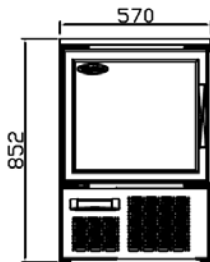

CONNECTIONS

MODELS	A (mm)	B (mm)	C (mm)	D (mm)
ESC50	600	135,5	-	-
ESC50CR	600	135,5	-	-

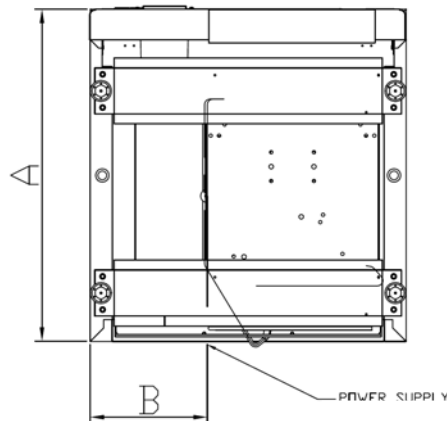

Review: 01 Date: 06/06/2013

WE RESERVE THE RIGHT TO CHANGE SPECIFICATIONS WITHOUT PRIOR NOTICE